

TIGER 6



AGROSALON



R Soil Protect



reddot design award
winner 2018



ROPA



The new superior class.



TIGER 6

- Proven design and innovative
- Harvest the complete beet crop
- 3.00 m width for harvesting without beet losses
- Excellent reliability – sturdy construction
- **Durable and with excellent residual value**
- New chassis design - greater operational safety in wet conditions
- Levelling on slopes and higher driving comfort
- New user-friendly cabin
- High tank capacity – high daily performance
- Reduced fuel consumption
- Less wear and tear
- **Higher soil protection**





Ergonomics and comfort,
the driver is at the centre.

R-Cab in the new design

The easy-care, pleasant and attractive interior of the new cabin guarantees the most comfortable operation. There are generously dimensioned shelves, storage compartments and plenty of space around the driver. A cooler and the integrated seat ventilation for hot days and seat heater for colder weather are standard equipment. Extremely powerful fully LED working lights turn night into day.

R-View video system (optional)

The rear part of the machine is displayed on the monitor in the bird's eye view. Obstacles are visible and collisions are avoided.





R Concept

Intuitive dual operating concept - ROPA combines under the name R-Concept its new intuitive operating philosophy. The large 12.1 inch touch screen is the information and command centre of the machine. From here the operator monitors the entire machine, receives information about operating conditions and performance data, adjusts functions and the working results of the machine. Dual operation either with fingertip on the touch screen or by turning and pressing the "R-Select" and "R-Direct" rotary buttons. The controls are situated in the ergonomically perfect position on the newly designed control panel und the handle of the multifunctional joystick (with integrated mini joystick). The thin control panel at the driver's position offers numerous adjustment options and supports the ergonomical and comfortable seat position with greatly improved all-round vision.

A premium workplace for driving pleasure.

R Select

Select important working functions

Grouped functions for intuitive selection and adjustment of all important functions during operation for quick and clear adjustment.

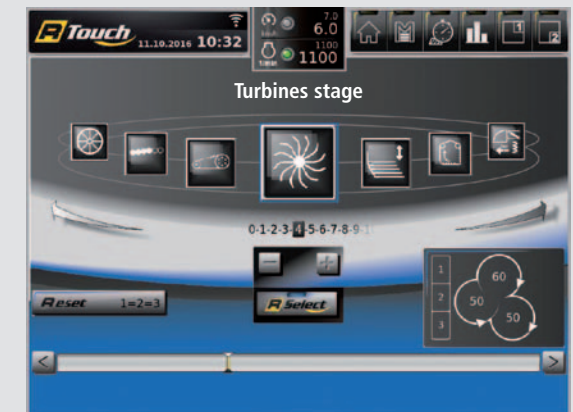



Directly in the terminal menu

Direct access to main menus and to detailed machine settings and data query in submenus.

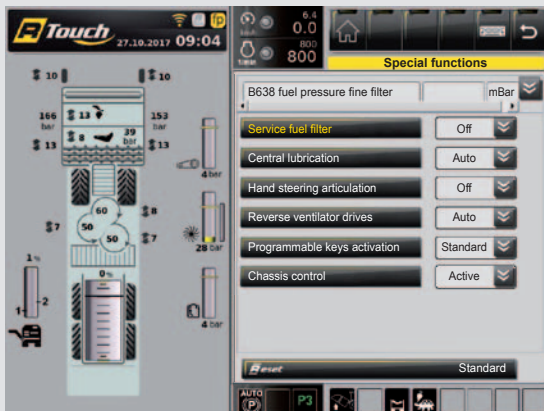
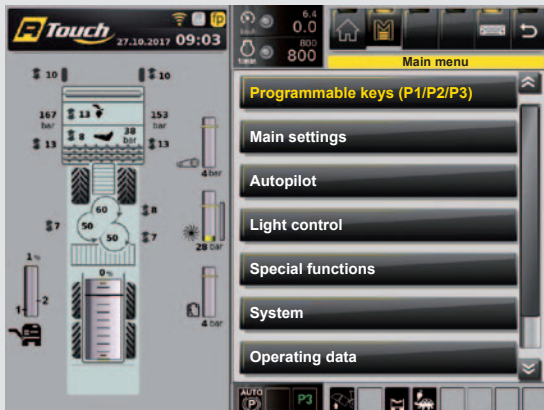

Lights menu

One or all working lights can be switched on only with a fingertip on the touch-terminal.

And again a one fingertip is enough to back up and recall three different lighting programs.

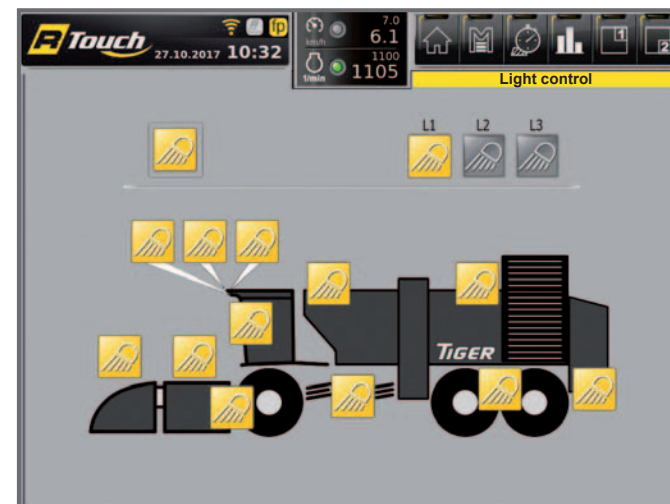

Automatic folding

A touch of the button is enough to "transform" the ROPA Tiger 6 automatically from road drive mode to field mode. Unloading conveyor, one metre wide ring elevator, bunker auger and other groups fold one by one, in some cases simultaneously. The sensor-controlled monitoring systems exclude operating errors and collisions. The entire folding process with simultaneous activation of all functions takes a very short time.





TIGER 6



Powerful LED lights turn night to day **10,000 lumens on the driver's cabin**

The redesigned and very spacious R-Cab driver's cabin has been significantly upgraded and is suspended on hydrobushings. It is oriented to the driver, who has the best overview of the redeveloped lifting unit from a physiologically appropriate and comfortable seating position.



Soil-protective hydraulic chassis system with new tyres technology

only 1.4 bar tyre inflation pressure for sustainable land management

R *Soil Protect*

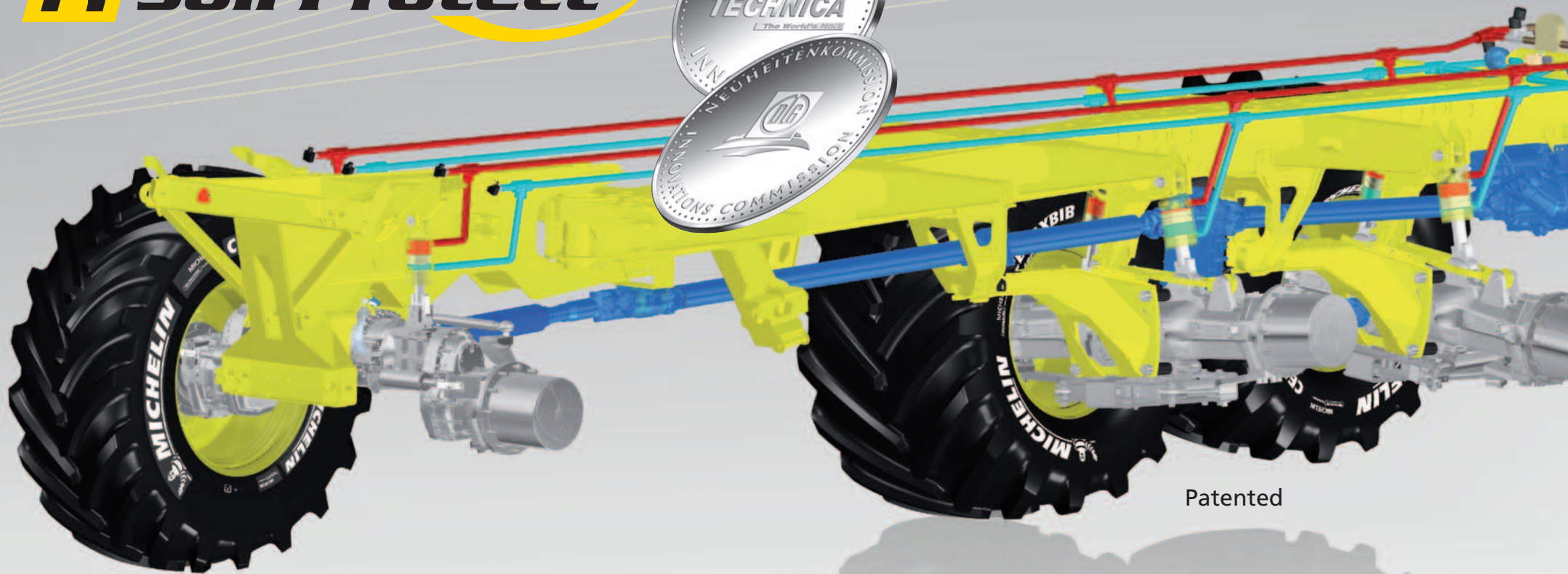

Awarded with silver medal at Agritechnica 2015.

R Soil Protect

ROPA R-Soil Protect is the combination of a soil-protective, hydraulic chassis system with new MICHELIN CerexBib tyre technology. This soil protection concept was awarded a silver medal at Agritechnica in Hanover. It only requires 1.4 bar tyre pressure and it is available as an option in the Tiger 6. The synergy of the load-balancing hydraulic chassis with the new generation of MICHELIN IF1000/55 R32 CerexBib tyres offers even more contact surface with sustained soil protection and significantly reduced contact pressure.

ROPA R-Soil Protect Innovations

- Significantly higher soil protection due to tyres inflation pressure reduced by 1 bar in comparison with euro-Tiger V8-4 - unique for root crop harvesting branch
- 49 % larger tyre contact area, 33 % less contact pressure thanks to IF1000/55 R32 CerexBib
- Significant reduction of load peaks by load transfer:
8 % less on the first axle, 37 % less on the second axle, 43 % less on the third axle
- Equal load distribution on all wheels by networked hydraulics
- On slopes, the load and the gravity centre of the slope bottom side are shifted to the slope top side
- Cleaning elements are guided horizontally also on slopes, providing perfect cleaning performance
- Soil-protective sugar beet harvesting also on the side slope without additional tyres inflation pressure increase
- Maintenance and protection of soil structure, ensuring infiltration capacity and air exchange

Summary: Resources and Soil Protection for Efficient Land Management

ROPA

Hydraulic connection of the stabilization cylinders at front and rear axles from the each side



R Soil Protect

Hydraulic chassis system - roll stabilization with load compensation - applied for patent

ROPA has developed an innovative chassis concept with an oscillating front axle in conjunction with two hydraulically supported rear axles specially for the flagship Tiger. Compared to the chassis on previous 3-axle beet harvesters (with the central axle fixed to the frame), this reduces the sway of machine by one third! The reason for the improvement is the hydraulic connection of the cylinders at the front and rear axles on one side, so unevenness at one wheel at a different level only affects the frame by 33 per cent compared to the previous system. Thanks to the reduction of the chassis swing, the row and depth control are improved simultaneously, as the frame is averaged to the position of three axles. The hydraulic connection of the axles always distributes the load equally over all 6 wheels.

The hydraulic chassis system minimizes tyres load and ground pressure, thus ensuring further reduction of tyre inflation pressure.

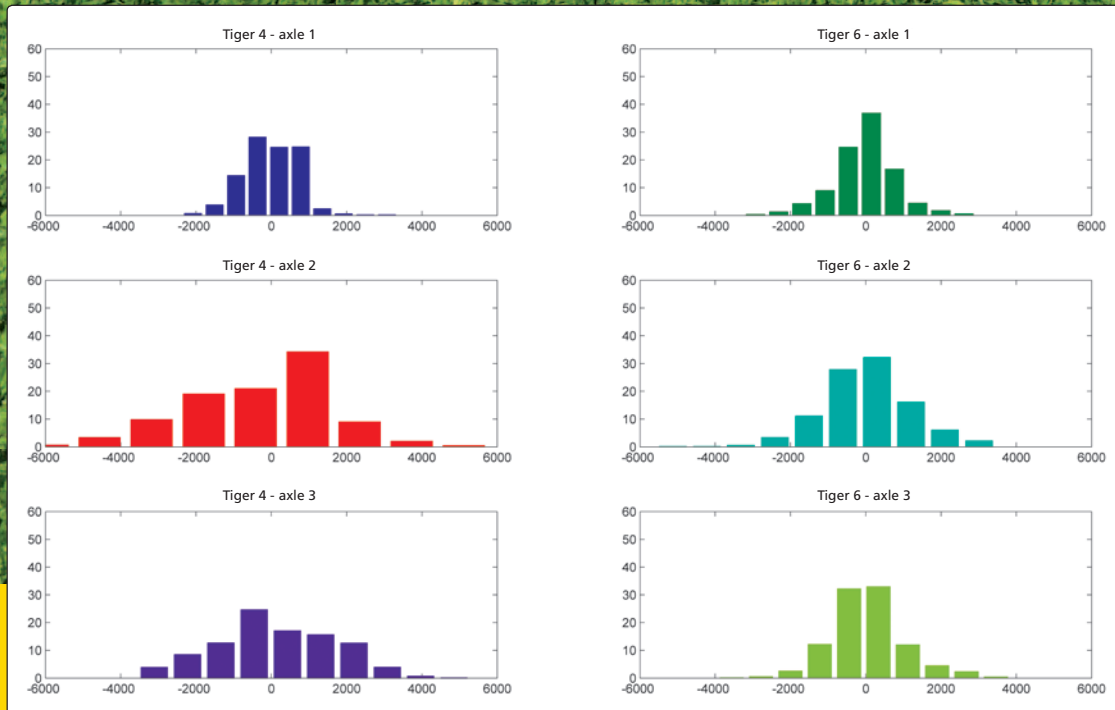

Horizontally: peak loads in kg during lifting at 7 km/h - Vertically: time in %

The new chassis reduces the load peaks by

- **8 %** at the 1st axle
- **37 %** at the 2nd axle
- **43 %** at the 3rd axle

ROPA

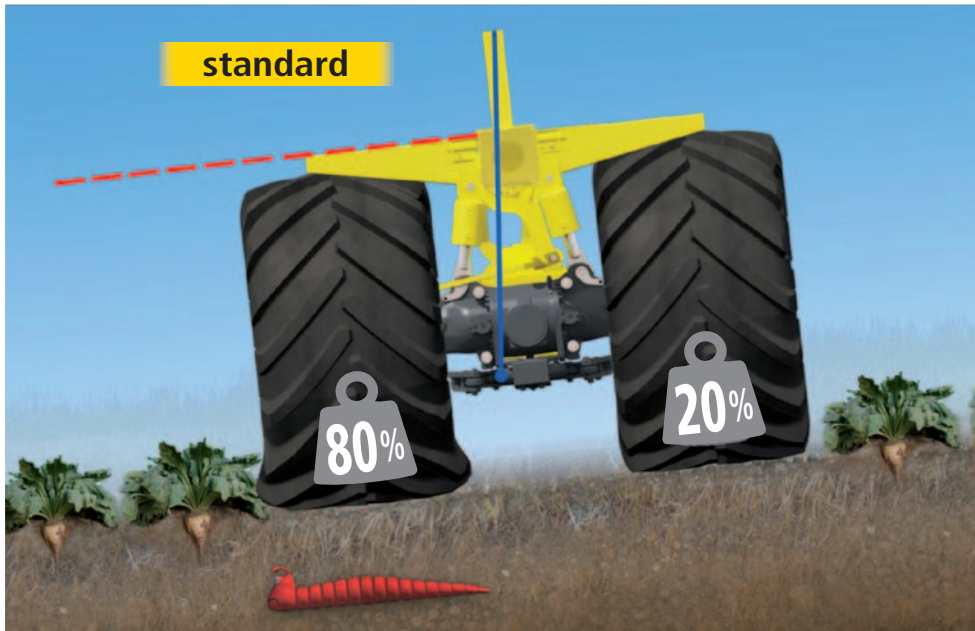

Slope compensation up to 10% - gravity centre / ground pressure are compensated

The automatic levelling system using six hydraulic cylinders and sensors is unique among 3-axle beet harvesters. The chassis is kept completely horizontally for up to 10 percent side slope. The gravity centre and, thus, the load of the wheels on the slope bottom side are shifted to the slope top side. The track depth of the wheels on the slope bottom side is substantially reduced, the infiltration capacity is retained, thus significantly reducing erosion risk during heavy rains.

The slope stability and traction increase greatly, the risk of tipping over is considerably reduced alongside with increased driving comfort. Soil-protective sugar beet harvesting also on the side slope without additional tyres inflation pressure increase!

On the slope, the load and the gravity centre of the slope bottom side are shifted to the slope top side: soil-protective sugar beet harvesting also on the side slope!

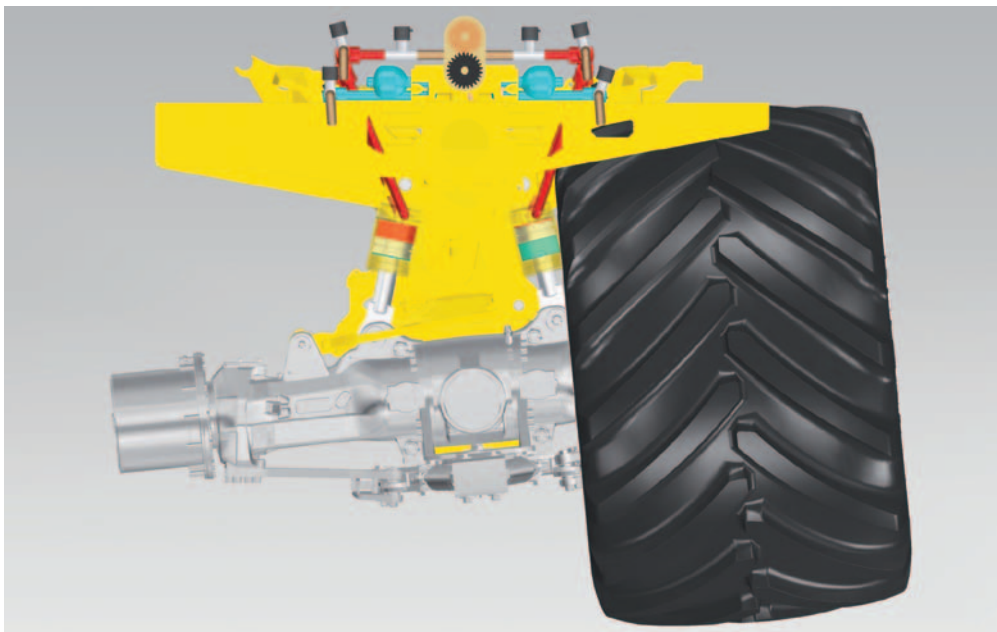

Hydraulic chassis, automatic slope compensation

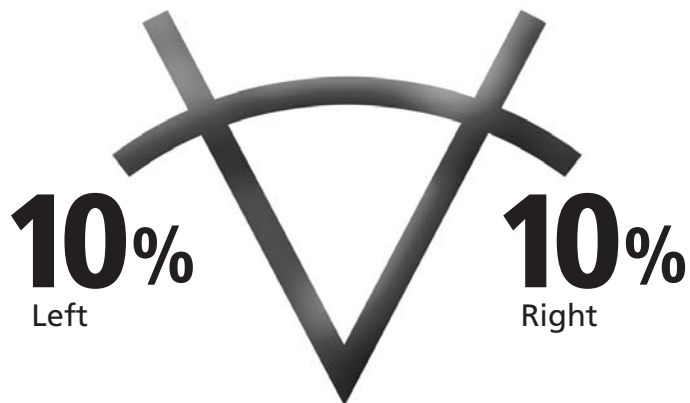

ROPA

Direct power transmission with cardan shafts ensures even traction on all wheels at very high torque

As a unique selling proposition on the market of 3-axle sugar beet harvesters, the Tiger has a direct power transmission via directly linear situated cardan shafts from traction drive to both rear axles and front axle, which is a great advantage for better traction in changing or difficult soil and harvesting conditions. Thanks to hydraulic chassis the load is always distributed evenly. Thus, lead or lag between the axles are consistently excluded.

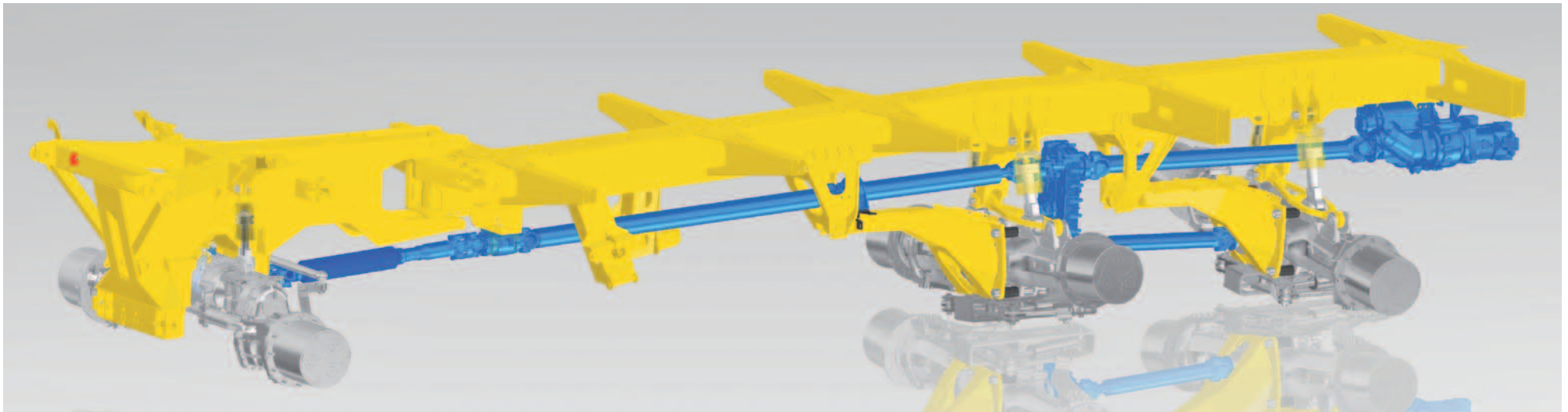

Stepless CVR gearbox for efficient power transfer

The new stepless traction drive was specifically developed by ROPA, Omsi and Bosch-Rexroth for the ROPA Tiger with its high drive power. The "constant variable ROPA" gearbox (CVR) consists of three hydraulic motors on a compound gearbox and is located between the engine compartment and the third axle. The maximum speed of 40 km/h can be reached by the Tiger 6 at an extremely economical 1195 rpm. Harvesting in the field can be performed at an engine speed of only 1,100 rpm. Depending on power requirements the rotational speed of the Tiger is automatically regulated up to 1,650 rpm. The multi-disk differential brakes integrated into the axles (protected from dirt) running in oil bath "tame" the Tiger as required.

**Even wheel load, uniform rolling circumference of rear wheels,
uniform traction distribution → optimal traction!**



R Soil Protect



ROPA

Significantly larger ground contact area for sustainable soil protection

The increased and soil-protective tyres of the new Tiger make him look very imposing. Good soil protection is maintained by Michelin 800/70 R38 Ultraflex tyres at the front axle and optional Michelin CerexBib IF1000/55 R 32 CFO tyres at the rear axles even with full bunker of about 43 m³ / 30 t. The soil is protected alongside with improved damping characteristics at only 1.4 bar of tyre inflation pressure in all six wheels.

Less ground pressure at the same loading

10800 kg cycl. at 15 km/h	1050/50R 32 MEGAXBIB	IF 1000/55R32CFO CEREXBIB	Bonus
Tyre inflation pressure	2.4 bar	1.4 bar	1 bar less

Ground contact area measurement at 10000 kg

	1050/50 R 32 MEGAXBIB	IF 1000/55R32 CFO CEREXBIB	Bonus
Tyre inflation pressure	2.1 bar	1.25 bar	- 40 %
Tyre contact area	5326 cm ²	7926 cm ²	+ 49 %
Ground pressure	1.87 kg / cm ²	1.26 kg / cm ²	- 33 %

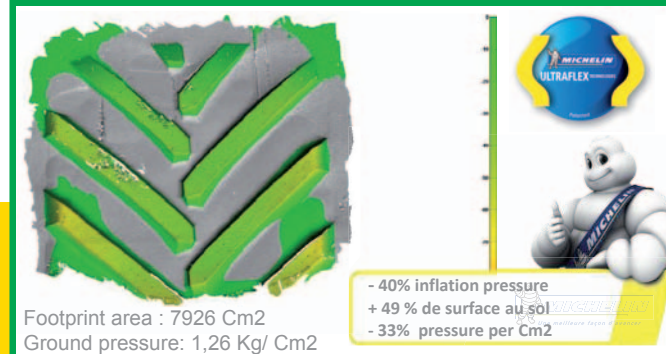
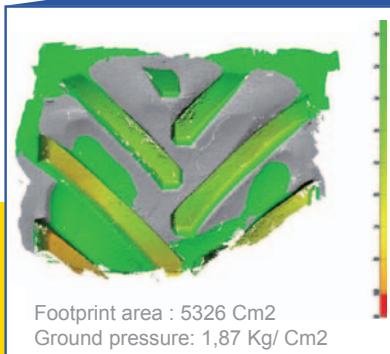

MICHELIN CerexBib IF1000/55 R 32 CFO is a new tyres generation for sustainable soil protection.



AGROSALON



R Soil Protect



reddot design award
winner 2018

TIGER 6



ROPA

Master of extreme terrain







PAS/RAS leaf ejection

ROPA all-round defoliator with leaf ejection

The beet leaves are shredded and transported by a leaf scroll to the leaf plate, which spreads them over the harvested area. A press of the button in the cabin switches the machine. An optional leaf collection conveyor can be installed for harvesting beet leaves (biogas or dairy).



PAS/RAS integral leaf diverter

ROPA all-round defoliator with integrated leaf diverter

The beet leaves are shredded and deposited between the rows. A press of the button in the cabin switches the machine between topping modes.



PIS/RIS - ROPA integral defoliator

ROPA integral defoliator - standard model for normal harvesting conditions

Leaves from the beet crowns are mulched with robust defoliator knives and spread between the rows. Therefore, beet leaves with all their nutrients are evenly delivered to the soil, the optimal basis for further soil cultivation as green waste is quickly converted to humus.



TIGER 6

ROPA

1535

ROPA

ROPA



Non-jamming PR lifting unit with hydraulic stone protection

The PR2h lifting unit is equipped with counter-rotating oscillating shares and completely maintenance-free hydraulic stone protection.

The 900 mm large depth-control wheels combined with the intelligent three-point suspension guarantee accurate depth control of the lifter. Minimum maintenance costs are required thanks to adjustable taper roller bearing in drives and oscillating share drive.

Micro-Topper

The sharp knife cuts off leaves, nothing is wasted, no beets are cut too low.







Proven, robust PR lifting unit



The robust PR lifting unit is designed for the toughest conditions. The defoliator can be lifted hydraulically 90° above the lifting unit for service and installation. It is lifted from the cabin by pressing a button without requiring the driver to leave the cabin, or from the ground by push button without needing to insert pins.

Hydraulic shaking share drive, with long-life adjustable taper roller bearings and very long drawbars.



ROPA PES/RES rubber-defoliator

The both fully hydraulic driven cleaning rotors can be adjusted in the rotation speed and height independently from the other – unique!

Various settings can be stored and accessed on the joystick using a memory function.





Weight-optimised RR lifter with single-row adjustment

The RR lifting unit is equipped with counter-rotating oscillating shares, seven lifting rollers, completely maintenance-free hydraulic stone protection and single-row adjustment of the lifting depth. The 850 mm large depth-control wheels combined with the intelligent three-point suspension guarantee accurate depth control of the lifter. Maintenance costs are minimised with adjustable taper roller bearings in transmissions and the oscillating share drive. The convenient maintenance position lifts the defoliator and the lifting group 90 degrees for simple inspection and service of defoliator knives, scalper knife and lifting shares

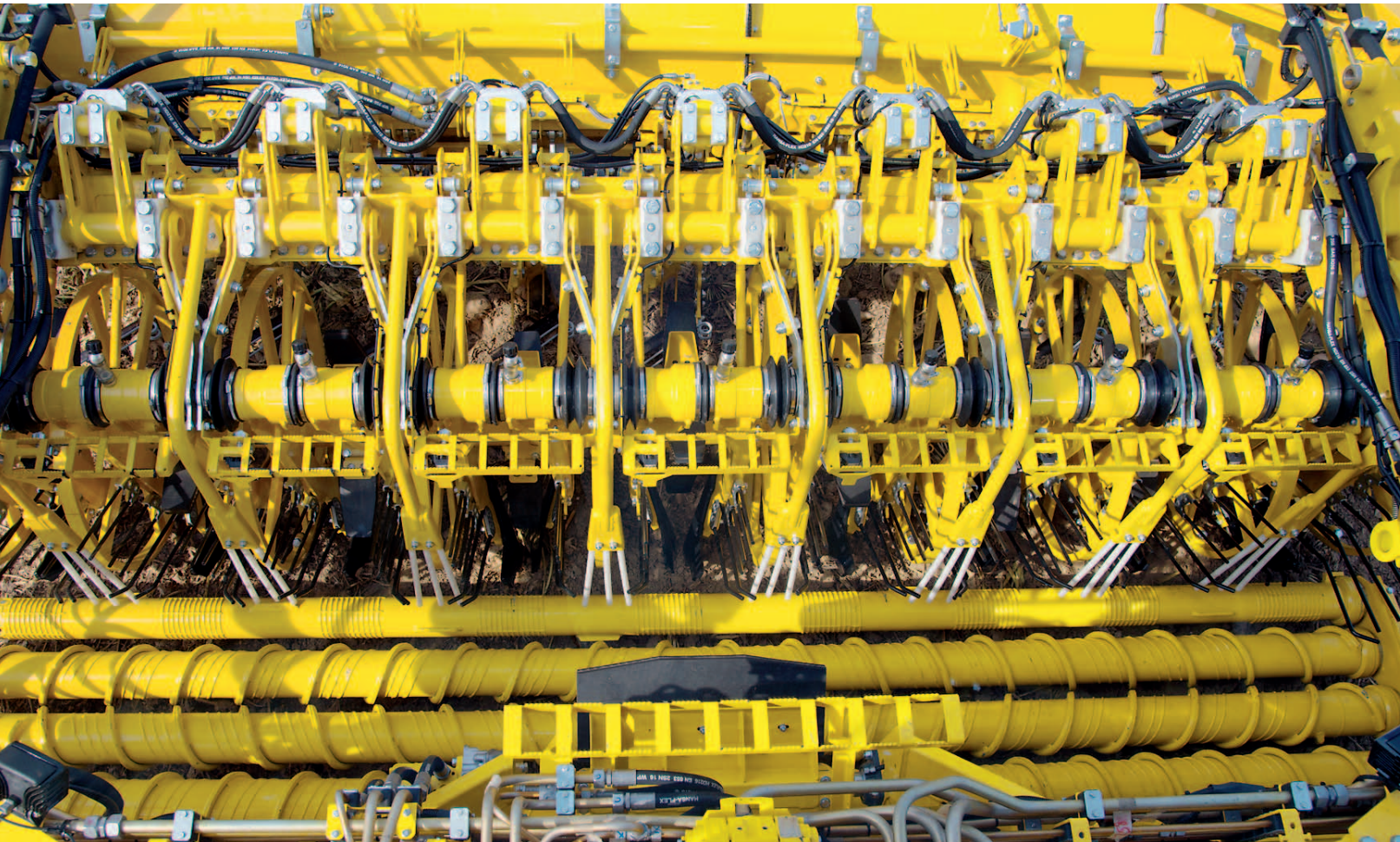





Convenient maintenance position - RR lifting unit

The defoliator can be lifted hydraulically 90° above the lifting unit for service and installation. It is lifted from the cabin by pressing a button without requiring the driver to leave the cabin, or from the ground by push button without needing to insert pins.

The engine can be started by pressing a button on the lifting unit and then the desired maintenance position can be set.





ROPA

TIGER

TIGER 6

TIGER 6

Tiger 6 XL - efficiency and power

The ROPA Tiger equipped with 8- or 9-row wide harvesting unit of the PR-XL series is capable of covering significantly larger areas at reduced harvesting speed. Advantages of this version are reduced fuel consumption, lower fixed costs and an improved topping quality. By attaching the wide PR-XL lifting units the front axle of the Tiger 6 can use even wider and more soil-protective 900/60 R38 Ultraflex tyres. Less passes and manoeuvres also contribute to soil protection.

Significantly higher area performance with reduced fuel consumption leads to lower costs during the profitable and efficient sugar beet harvesting season. Less passes and manoeuvres also contribute to better soil protection.



TIGER 6 XL





TIGER 6

XL

40

ROPA

Concept



Cleaning - gentle, efficient and individually adjustable

The hydraulically tensioned web infeed conveyor efficiently transports the beets to the first turbine. The portal axis enable maximum throughput without slowing the beet flow or damaging the beets. The driver can steplessly adjust the web infeed conveyor speed and reverse it if necessary from the cabin. The automatic beet flow monitor reliably prevents the beets from overflowing the machine. Three turbines with forged tines and offset carrier tines clean the beets extremely efficiently and then transport them to the next stage.

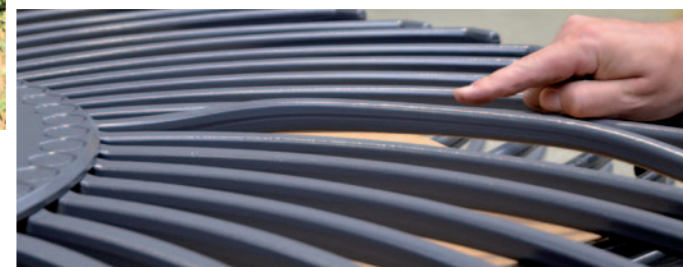

43 m³ large beet bunker

The automatic bunker filling allows optimum traction under all harvest conditions by excellent weight distribution. Two ultrasound sensors measure the yield, total the bunker charges, and save the result in the order database.





Extremely long unloading conveyor – faster tank unloading

The new extremely long unloading conveyor is located between the two rear axles and can be raised further due to higher tyres. It is a great advantage when loading on trailers driving alongside, because the transfer angle is shallower. The unloading conveyor is 3-way foldable and 2000 mm wide for even simpler application with 10-metre-wide piles or easy loading on trailers. The bunker unloading, which compared to the Tiger 5 is even more powerful, ensures faster loading on the move. Gentle polyurethane fingers guarantee high feeding capacity with short unloading times of less than 50 sec. with a full beet bunker holding more than 43 m³. The automatic bunker filling allows optimum traction under all harvest conditions by excellent weight distribution. Two ultrasound sensors measure the load by totalling the bunker loads and save it in the order database.

Fast trailer loading, gentle and convenient bunker unloading





TIGER 6

TIGER 6

40

Volvo Penta D16 with 700 hp/515 kW and 16.12 litre displacement

Power is transmitted even more efficiently with the 700 hp/515 kW ROPA Tiger 6 with its Volvo 6-cylinder inline engine (emission level EPA 4 final), 16.12 litre capacity, pump nozzle injection (PNI), SCR catalytic converter and AdBlue.

The maximum torque is 3200 Nm at 1260 rpm. From as low as 1000 rpm the engine offers a powerful 3150 Nm of torque. Harvesting is performed at an economical 1100 rpm with 3150 Nm torque - 11 percent greater than the Tiger 5 with 2840 Nm.

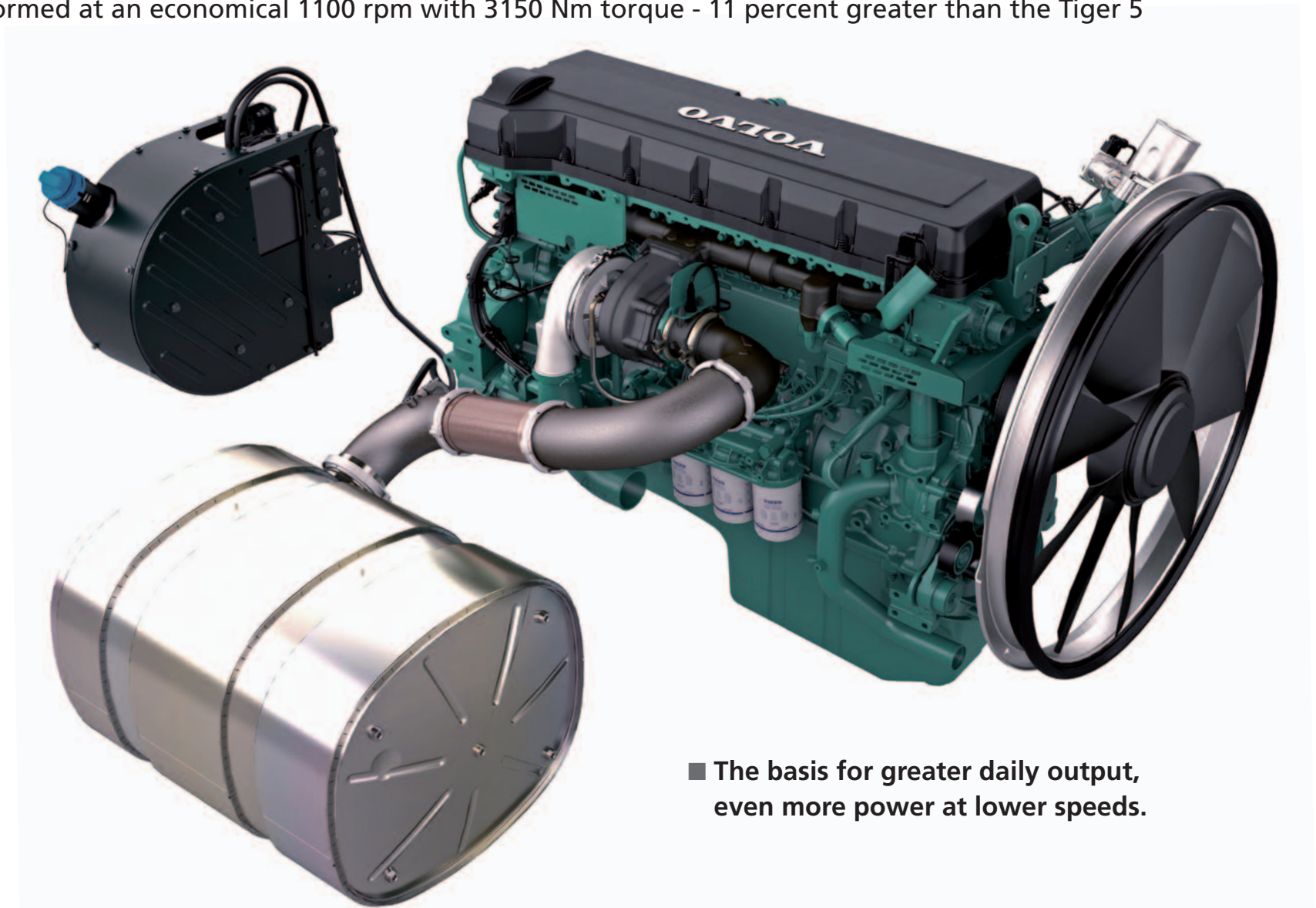

■ The basis for greater daily output,
even more power at lower speeds.



Volvo Penta D16 with 768 hp/565 kW and 16.12 litre displacement

For those who need even more power in the Tiger 6, ROPA offers the 768 hp/565 kW Volvo 6-cylinder inline engine with 16.12 litre capacity and pump nozzle injection (PNI) in the range. The robust power pack does not require AdBlue, SCR catalytic converter and exhaust gas recirculation. This reduces logistics requirements for equipment and minimises downtime.

A powerful maximum torque of 3260 Nm - 12 percent greater than the Tiger 5 with 2900 Nm - transmits power at optimal efficiency over the continuously variable transmission. The 142 hp/105 kW extra power compared to the ROPA Tiger 5 results faster hectare coverage, particularly when lifting uphill, during trailer loading while moving or with more than 6-row lifting with XL lifter units.

- **The basis for even higher daily output, increased operating safety.**

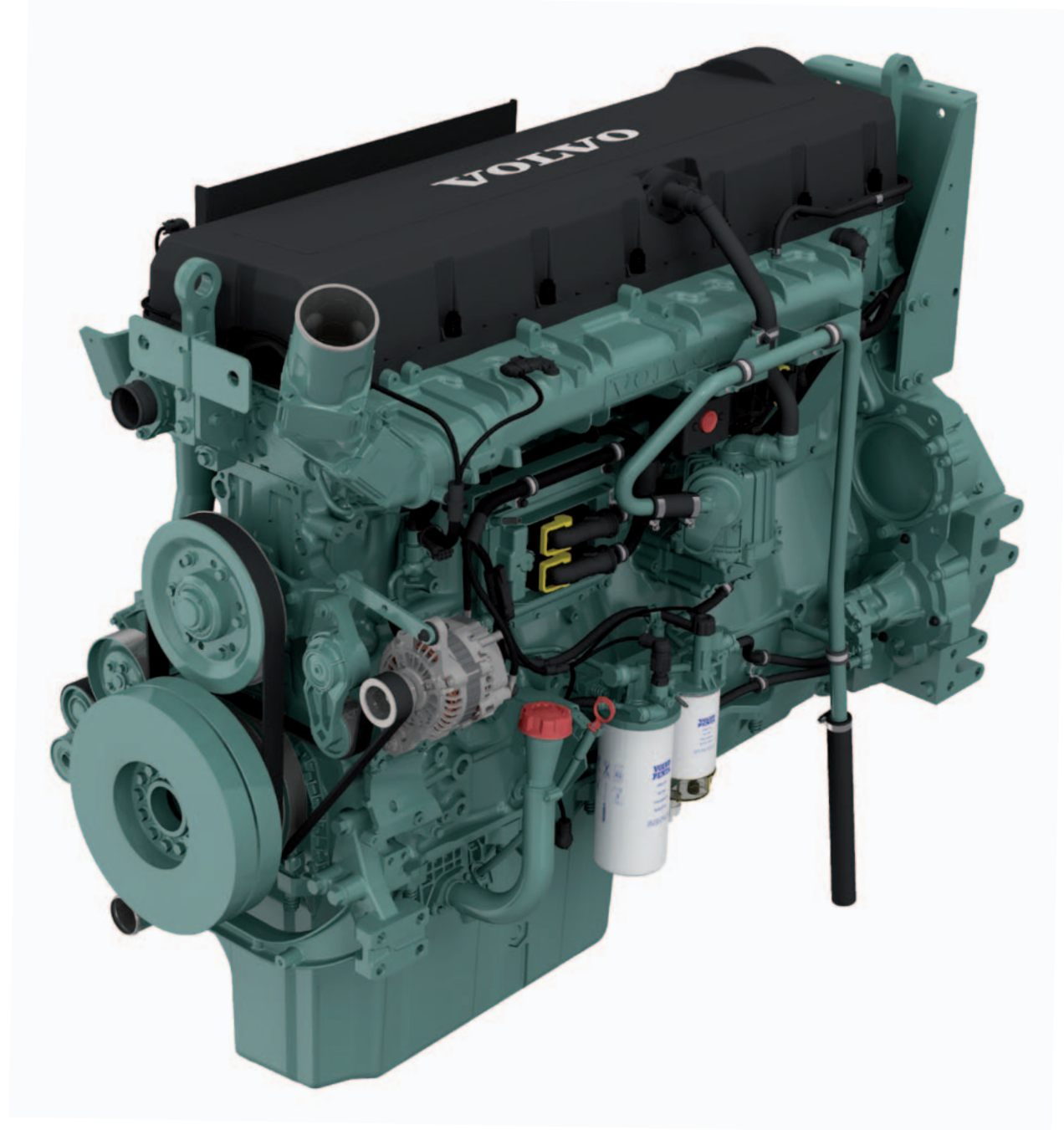

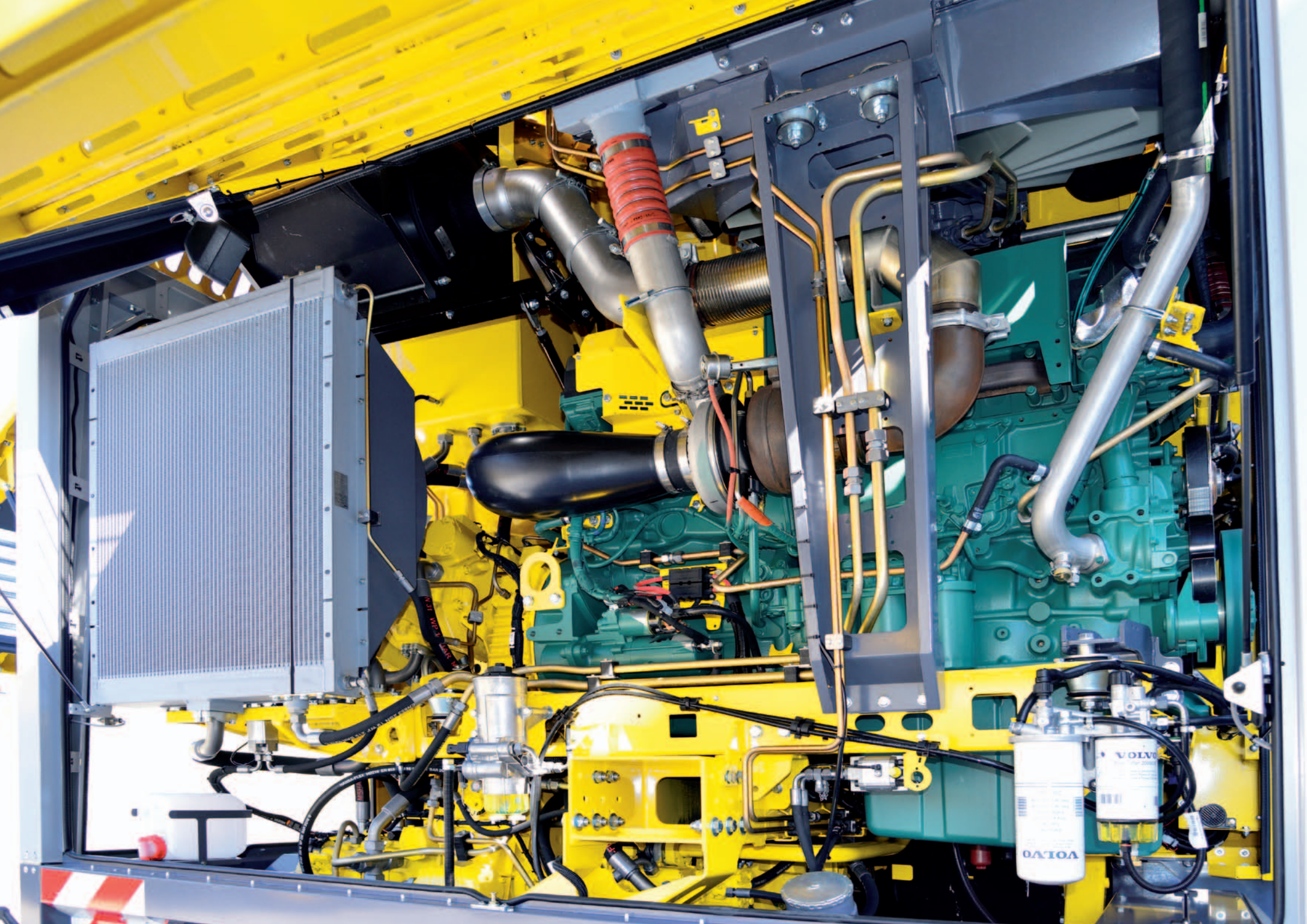



Technical Data of ROPA Tiger 6

Tiger 6c engine:

Volvo Penta D16, 700 hp/515 kW

16.12 l displacement, 6-cylinder inline engine, pump-nozzle injection (PNI)
EPA Tier 4 final emission level or emission level IV, SCR catalytic converter and AdBlue, maximum fuel sulphur content 15 ppm required to meet exhaust emission standard
Max. torque 3,200 Nm, working speed 1,100 rpm, automotive to max. 1,650 rpm

Tiger 6a engine (not for USA and Canada):

Volvo Penta D16, 768 hp/565 kW

16.12 l displacement, 6-cylinder inline engine, pump-nozzle injection (PNI), WITHOUT AdBlue, WITHOUT exhaust gas recirculation, fuel with sulphur content to max. 5,000 ppm permitted
Max. torque 3,260 Nm, working speed 1,100 rpm, automotive to max. 1,650 rpm

Cooling system:

Horizontal side-by-side radiator elements for intercooler and water, CVR oil cooler and air-conditioning condenser above (can be lifted off), radiator positioned at top rear for protection from dirt, hydraulic oil cooler with open fan, hydrostatically driven stepless and automatically reversing fan

Traction drive:

Traction drive with stepless CVR gearbox for efficient power transmission consisting of three hydraulic motors on the compound gearbox, continuous from 0 to 40 km/h without power interruption (no gear change or switching), 40 km/h in road mode at 1195 rpm, 17.5 km/h in the field at 1220 rpm.

Chassis - R-Soil Protect:

Innovative chassis design with oscillating front axle in conjunction with 2 hydraulically supported rear axles

Slope adaptation:

The chassis can be inclined by 10% to the slope on each side by 6 hydraulic cylinders. The slope compensation is automatically regulated by two inclination sensors (optional)

Chassis roll stabilisation:

Roll stabilisation by hydraulic compensation of oil level in the stabilisation cylinders on each side of the vehicle.

Tyres:

1st axle:
Michelin CerexBib 800/70 R38 (1.4 bar)
2nd and 3rd axle
Michelin MegaXBib 1050/50 R32 (1.9 bar)
Optional
Michelin CerexBib 1000/55 R32 (1.4 bar)

Large tyre contact surface protects soil and allows high operating reliability even in wet conditions and on slopes

Hydraulics:

Pump distributor gears with pressurized air lubrication and transmission oil cooling system, Bosch-Rexroth traction drive, high-capacity load sensing hydraulics from Bosch-Rexroth, Bucher and Hydac.

Cabin:

Sound-insulated and tinted all-round glass with low-line vision, quiet stepless fan in heating and ventilation system (climate control

air-conditioning), air-sprung GRAMMER ROPA Evolution seat with heating and active ventilation, autopilot, cruise control, base console for telephone, AM/FM/CD/USB/Bluetooth/DAB+ radio with external microphone for hands-free system, 14 litre cooling box

Operation:

R-Concept operating console, joystick operation, 12.1" R-Touch colour terminal, machine diagnostics including DM1 error messages from diesel engine in plain text fully integrated in R-Touch, 2 LED interior lights, full-surface window wipers, colour display for reverse camera

Defoliator unit:

PIS - integral defoliator unit with leaf spreading between beet rows, 2 depth-control wheels

PAS - all-round defoliator unit, push-button operation from the driver's seat, can be changed for either integral topping or leaf ejection to the left, 2 depth-control wheels (4 depth-control wheels as option)

PBS - defoliator unit with leaf ejection to the left, leaf-spreader and 2 depth-control wheels (4 depth-control wheels as option)

PES - rubber defoliator with leaf spreading between beet rows, 2 depth-control wheels

PR2h lifting unit:

6, 8 or 9-row, 45 cm, 50 cm or variable (with 6-row only), hydraulic stone protection, 90 cm depth-control wheels, 6 lifting wheels, stepless, fast shaking share drive with axial

piston motor, adjustable taper roller bearings in shaking share drive and lifting unit gears, variably adjustable distance between fourth and fifth lifting roller, good view of the lifting unit and scalper without additional cameras; service position allows defoliator to be lifted 90 degrees for best possible inspection and service of defoliator knives, scalping knife and lifting shares

RR lifting unit:

6, 8 or 9-row, 45 cm, 50 cm or variable (6-row only)
hydraulic single-row adjustment of lifting depth, hydraulic stone protection, 85 cm depth-control wheels, 7 lifting rollers, fast, stepless shaking share drive with axial piston motor, adjustable taper roller bearings in shaking share drive and lifting gears, excellent view of lifting unit and scalper without additional cameras, service position allows defoliator and lifting group to be raised 90 degrees for best possible inspection and service of defoliator knives, scalping knife and lifting shares

Cleaning:

Infeed conveyor: 800 mm wide, 50 mm pitch
1st turbine: 1700 mm diameter
2nd turbine: 1500 mm diameter
3rd turbine: 1500 mm diameter
Forged turbine tines

Turbine gates:

Height independently adjustable at 1st, 2nd and 3rd turbine, guide grids can be replaced with spring tines segment by segment



Elevator: 1000 mm wide

Electrics:

Integrated net of 24 volt, generator of 150 amps, 24 Hella LED operating lights, coming home light function, 2 x 12 volt sockets for radio or telephone etc., CAN-BUS computer system with integrated diagnosis of all components connected to the terminal, software update per USB interface possible.

Unloading conveyor:

3x folding, for even simpler pickup of 10 metre clamps, beet-protecting PU fingers for high throughput and short unloading times, both conveyors steplessly speed-controlled, longitudinal conveyor with quick-motion switch, unloading conveyor width 200 cm for even easier loading on trailers, bunker empties in less than one minute, trailer loading height up to 4.00 m

Bunker capacity: over 43 m³/30 t

Yield indicator:

2 ultrasound sensors measure the bunker content, full bunkers (and partly loaded bunkers) are added up and automatically recorded in the yield database.

Measurements:

Length: 14.99 m
Height: 4.00 m (transport mode)
Width: 3.00 m (6-rows at 45 cm per row),
3.30 m (6-rows at 50 cm per row
and 45-50 cm variable)

Fuel tank:

1320 l, fuel consumption displayed in l/ha and l/h on the terminal

AdBlue tank:

145 l (Volvo Penta 700 hp/515 kW only)

Unladen weight:

From 33,400 kg, depending on equipment

Equipment:

standard

Central lubrication system, fuel consumption measurement, air-conditioning, manual slope compensation, 40 km/h

Optional

Leaf spreader with stone protection, skids at scalper, RR lifting unit, Widia lifting shares (forged), hard-welded lifting rollers, guide grid segments with spring times in turbines 1-3, agitator in 2nd turbine, turbine camera, unloading conveyor camera on 2nd video display left, 2 LED high-beam headlights, data printer; via Wi-Fi Connect: R-Transfer Basic with data export to the ROPA app or USB stick, R-Transfer Professional with data import and data export to the ROPA app or USB stick, R-View video system (bird's eye view), GPS speed sensor, leaf pile equipment (only with defoliator with leaf auger), automatic slope compensation, contour marking package, additional chassis (required in Germany), maximum speed 32 km/h, 25 km/h

Correspond to TÜV, Trade and CE regulations. Subject to technical changes.

Existing protective covers have been partially dismantled for better imaging. The machine must not be operated without these covers!





ROPA Fahrzeug- und Maschinenbau GmbH

Sittelsdorf 24 · D-84097 Herrngiersdorf

Tel.: +49 (0) 87 85 / 96 01 - 0

www.ropa-maschinenbau.de